

# HTX 47

## SPECIFICATIONS

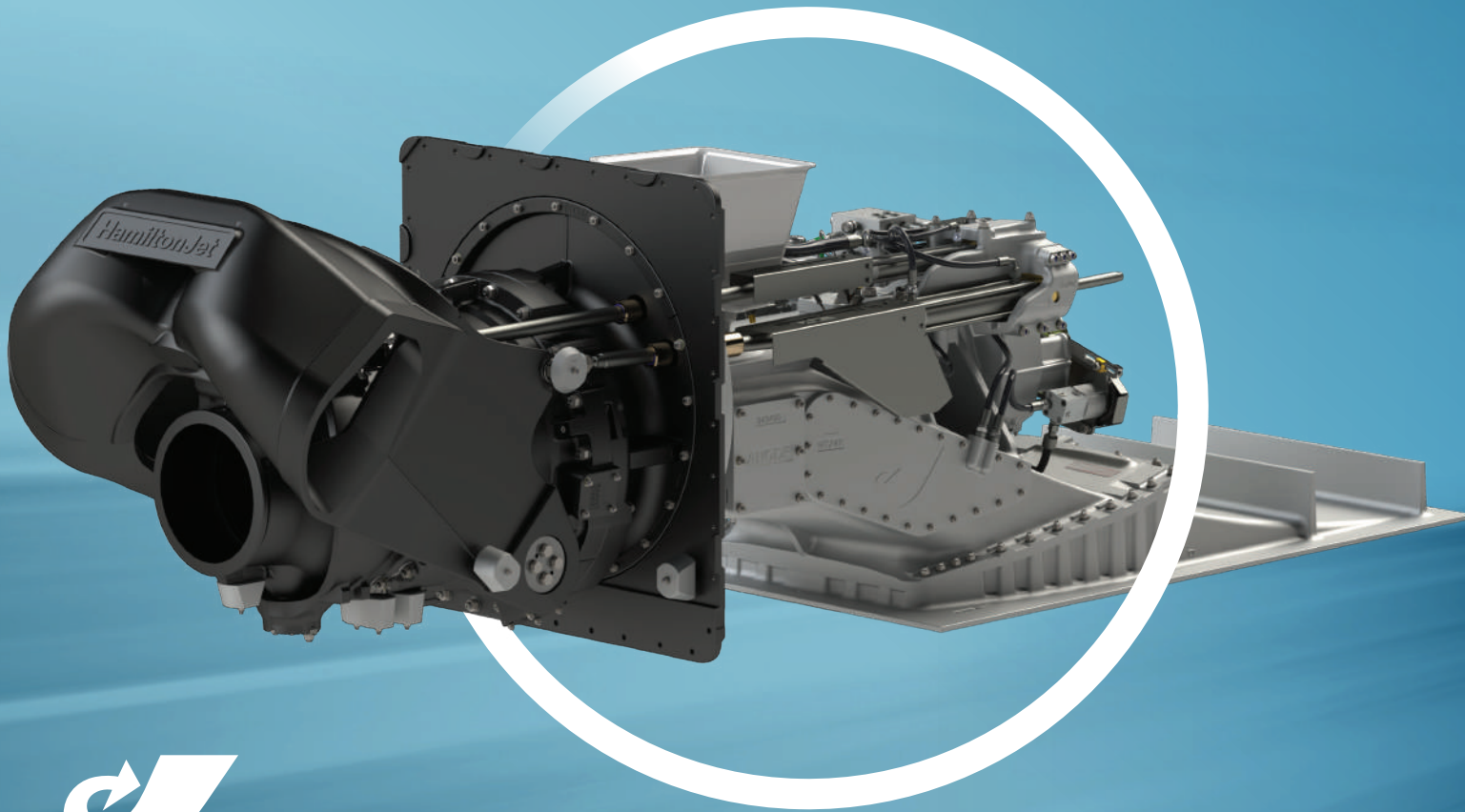

  
**HamiltonJet**

The Ultimate in  
Waterjet Sophistication

# HTX47

## SPECIFICATIONS

The HTX47 is the latest jet in the new generation of waterjets. The entire series features redefined performance, enhanced durability and easier installation.

### HTX47 features:

- Max Input Power: 1630 kW / 2186 hp
- Max RPM: 1743 rpm
- COG FWD of Transom - Dry: X = 214mm  
Y=494mm (not incl. Trans duct & screen)
- Max Speed: 50+ Knots
- Jet Type: Mixed Flow
- Jet Weight – Dry: 1093 kg / 2409 lbs
- Jet Weight – Wet: 1390 kg / 3064 lbs
- Transition Duct Weight: 80 kg / 176 lbs
- Jet Construction: Marine Grade Aluminium / Duplex & Super Duplex SS
- Shaft Angle: 0°
- Classification: DNV – Others Available on Application
- New Hydrodynamic Design delivers 4% more High Speed Efficiency
- 16% Increase in Peak Bollard Pull
- Better Minimum Speed
- Enhanced Corrosion Protection
- Compact Inboard Footprint with fully Integrated Hydraulics
- Increased Impeller Rating Range for Compatibility with Wider Range of Engines
- Available with AVX Controls

COMPONENT	MATERIAL	STANDARD
Intake Block	EN AC 44100 Cast Marine Grade Aluminium	BS EN 1706
Intake Material	EN AC 44100 Cast Marine Grade Aluminium	BS EN 1706
Stator Material (without LEI)	EN AC 44100 Cast Marine Grade Aluminium	BS EN 1706
Nozzle Material	EN AC 44100 Cast Marine Grade Aluminium	BS EN 1706
Steering Deflector Material	EN AC 44100 Cast Marine Grade Aluminium	BS EN 1706
Astern Deflector Material	EN AC 44100 Cast Marine Grade Aluminium	BS EN 1706
Jet Weight – Wet	EN AC 44100 Cast Marine Grade Aluminium	BS EN 1706
Mainshaft Material	2205 Duplex Stainless Steel	ASTM 276
Wear Ring Material	2205 Duplex Stainless Steel	ASTM 240
Impeller Material	CF8M Cast Stainless Steel	ASTM A743
Anode Material	High Energy Aluminium (Internal and External)	

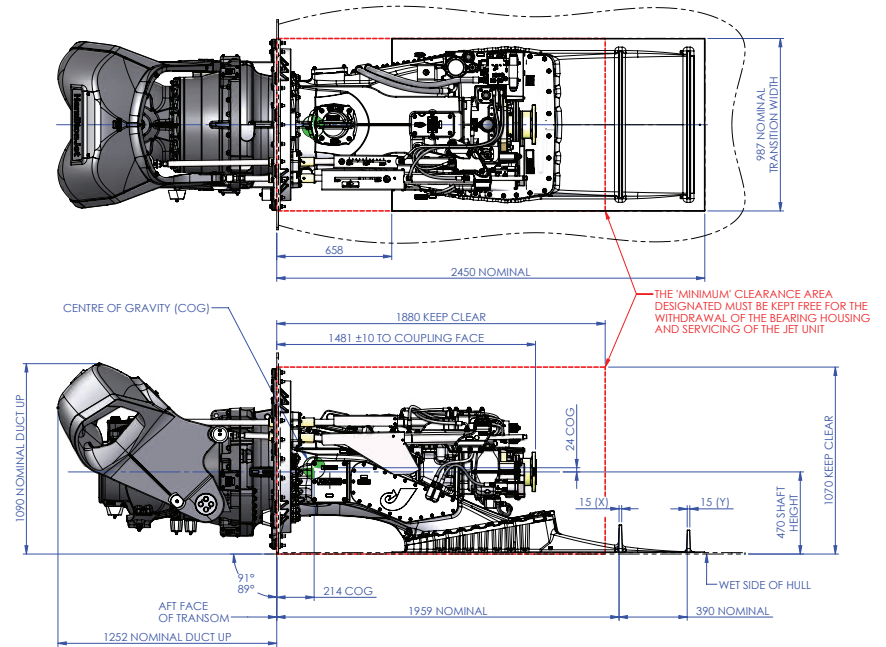

**IMPORTANT NOTES:** The HJX47 dimensions shown above are Indicative and Preliminary dimensions only for initial design purposes, and subject to change without notice or obligation. Please consult with the factory before using these preliminary dimensions for final installation requirements as these may have changed. Waterjet selection is determined by a range of hull and operational factors, most importantly vessel size and displacement (weight), and not necessarily by matching the above specifications to the desired engine power/RPM curve. In all cases you should consult HamiltonJet for assistance with waterjet selection.

